

Oil leader's item 49 & 50 & shim item 70 to be used on all 600 RAM units without revised headplate. 600 RAM units with the revised headplate do not require items, 49, 50 & 70. All 400 & 600 RAM/RCS & 600 RCS units require items 49, 50 & 70.

SEE NOTE No. 3

SEE NOTE No. 4

NOTES:

1. DRIVE END COVER TO BE PINNED TO HEADPLATE AFTER ALIGNING SEAL BORE WITH SHAFT WITHIN .001
2. USE JOHN CRANE PLASTIC LEAD No. 2 ON ALL PIPE THREADS
3. ITEMS 34 & 54 MUST BE INSTALLED WITH OIL GROOVE AT TOP
4. TORQUE: 400 RCS TO 400 LBS. FT.
600 RCS TO 630 LBS. FT.
5. TORQUE: 400 RCS TO 75 LBS. FT.
600 RCS TO 140 LBS. FT.

APPLY LOCKTITE TO SCREW THREADS AND BOTH FACES OF WASHER AND SLINGER

REF 64676023

G INCREASED GEAR NUT TORQUE JHB 3-29-90 3577-V
 F REVISED PER ECN RVE 027 3483-V FCR AP DB 4-19-86
 E REVISED PER ECN RVE 1202 3436-V DB AGP FCR 6-05-86
 D ITEM #63 600 ONLY REVISED REM 11/21/80 3367-VFCR DLB 6-07-86
 C REMOVED ITEM 36 WASHER REM 02/19 3337-VFCR AP
 B DOWEL PIN DIMENSION ADDED REM 2/25/80 3246-VFCR AP
 A ADDED 409 AND ABOVE REM 10/16 6°±11° FCR AP PARTS/XXAS

SECTIONAL ASSEMBLY
400 & 600 RCS-V

65467023

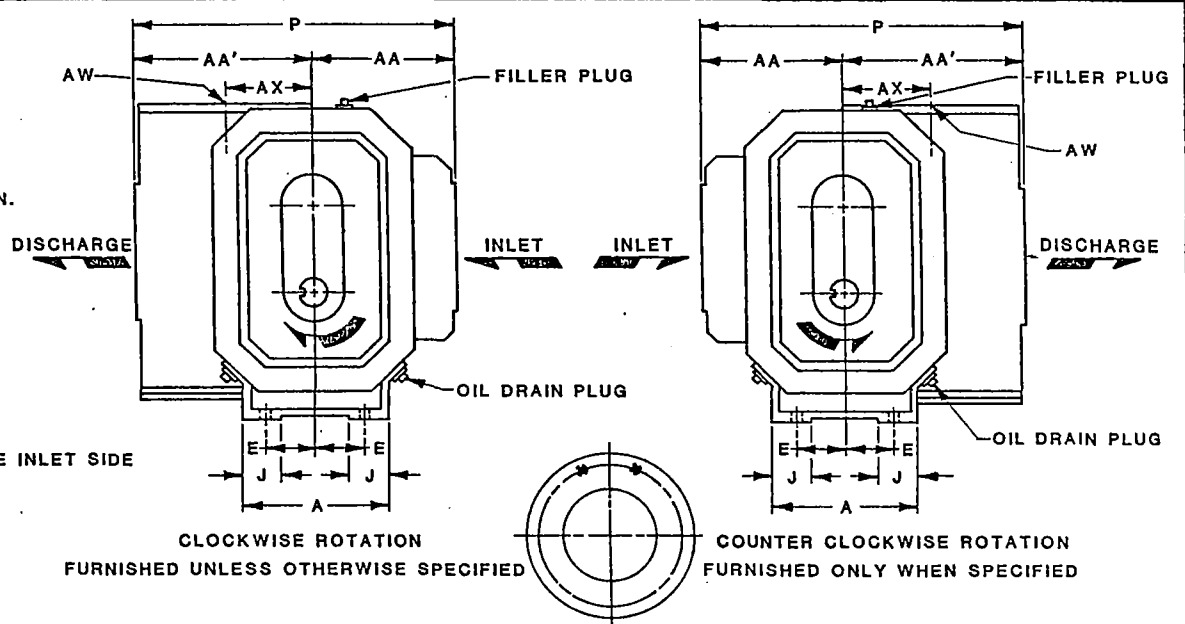
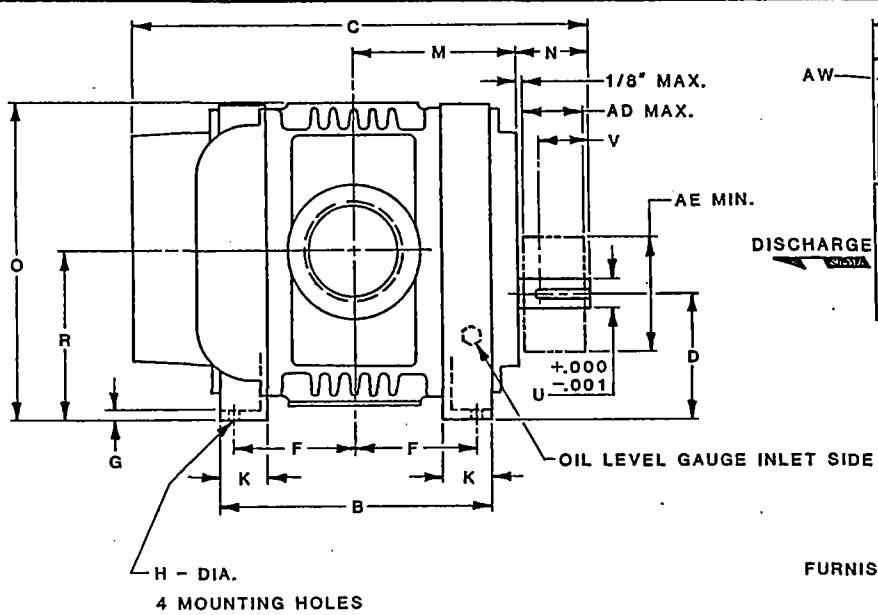

INLET AND DISCHARGE FLANGES TO MATE
 FLUSH AND SQUARE WITH FLAT FACE
 FLANGE ONLY. USE FULL FACE GASKET.

FOR V-BELT DRIVEN UNITS, MOTOR
 TO BE LOCATED ON INLET SIDE OF
 OF BLOWER.

	5" FLG.	6" FLG.	8" FLG.	10" FLG.
OPENING	5.00	6.00	8.00	10.00
BOLT CIRCLE	8.50	9.50	11.75	14.25
FLANGE O.D.	10.30	11.00	13.50	16.00
NO. TAPPED HOLES	8	8	8	12
SIZE HOLES	3/4-10	3/4-10	3/4-10	7/8-9
TAP DEPTH	1.13	1.13	1.13	1.31

W - INLET
 W' - DISCHARGE
 AD - SHEAVE WIDTH
 AE - SHEAVE DIAMETER
 AW - JET INLET

DVJ DRY VACUUM WHISPAIR BLOWER-BOTTOM DRIVE

SIZE	A	B	C	D	E	F	G	H	J	K	M	N	O	P	R	U	V	KEYWAY	W	W'	AA	AA'	AD	AE	AW	AX	OIL CAPACITY	APPROX. WEIGHT
406 JV	7.50	10.88	20.38	6.75	2.50	4.75	.50	.44	2.00	2.44	7.13	3.31	16.63	17.75	9.00	1.50	2.75	.375 x .188	4" NPT	5" NPT	7.25	10.50	3.53	6.50	4" NPT	6.75	32.5 FL.OZ.	365
412 JV	7.50	16.88	26.38	6.75	2.50	7.75	.50	.44	2.00	2.44	10.13	3.31	16.63	17.75	9.00	1.50	2.75	.375 x .188	6" FLG.	6" FLG.	6.00	11.75	3.53	6.50	5" FLG	6.50	32.5 FL.OZ.	575
616 JV	10.00	21.44	32.50	9.00	3.50	9.75	.63	.56	2.50	2.75	12.56	4.19	21.63	21.25	12.00	2.00	3.63	.500 x .250	8" FLG.	10" FLG.	7.50	13.75	4.44	8.50	8" FLG	6.75	70 FL.OZ.	975

ALL DIMENSIONS IN INCHES

CERTIFIED CORRECT FOR
 CUSTOMER ORDER NO. _____
 ROOTS ORDER NO. _____
 DATE _____

V-BELT DRIVE DATA

BELTS _____
 DRIVE SHEAVE _____
 DRIVEN SHEAVE _____
 CENTER DISTANCE _____



DRESSER INDUSTRIES, INC.
 ROOTS DIVISION
 900 WEST MOUNT STREET,
 CONNERSVILLE, INDIANA 47331

REM 9/17/86
 FLK

865-637-021