

- NOTES:**
1. DRIVE END COVER TO BE PINNED TO HEADPLATE AFTER ALIGNING SEAL BORE TO SHAFT WITHIN .001"
 2. USE JOHN CRANE PLASTIC LEAD No. 2 ON ALL PIPE THREADS
 3. APPLY OIL TO NUT THREADS & NUT FACE AND TORQUE TO 1250 FT-LBS. (IF MOLYKOTE GN PASTE IS USED TORQUE TO 1000 FT-LBS.)
 4. APPLY LOCKTITE TO SCREW THREADS & TORQUE TO 140 FT-LBS.
 5. APPLY LOCKTITE TO SCREW THREADS & TORQUE TO 25 FT-LBS.
 6. APPLY OIL TO SCREW THREADS & TORQUE TO 85 FT-LBS.
 7. ITEMS 34 & 54 MUST BE INSTALLED WITH OIL GROOVE AT TOP.

OPTIONAL BOTTOM DRIVE

CONFIDENTIAL THIS DOCUMENT CONTAINS CONFIDENTIAL INFORMATION OF DRESSER DIVISION, DRESSER INDUSTRIES, INC. IT SHALL BE HELD IN STRICTLY CONFIDENTIAL AND BE LOANED ONLY IN CONNECTION WITH DRESSER DIVISION BUSINESS.		REVISED PER DD4 REVISED: OIL, S. HUBERT	DATE/REV. 1 03 24	REV. 2 03 24	REV. 1 03 24	REV. 1 03 24	REV. 1 03 24	REV. 1 03 24	REV. 1 03 24
SECTIONAL ASSEMBLY 700 (720-1)									
72015023									

Sectional Assembly 700

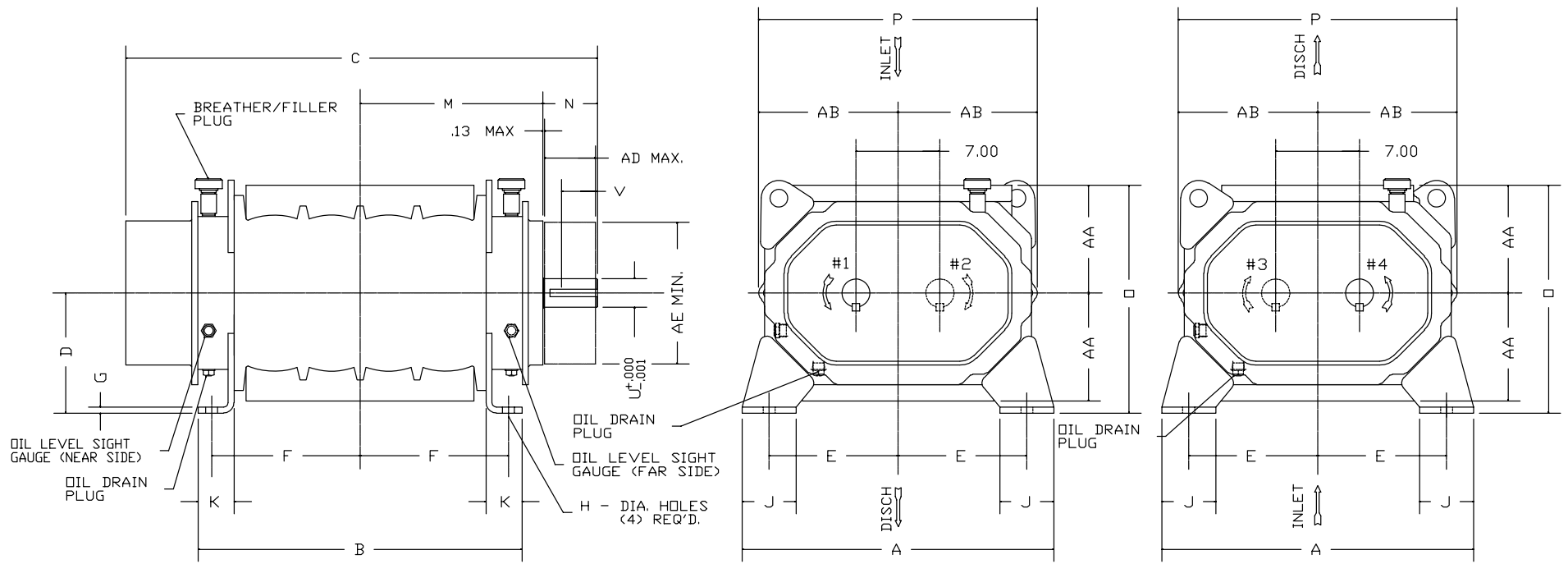

POSITION #1 FURNISHED
UNLESS SPECIFIED OTHERWISE

ALTERNATE POSITIONS #2, #3 & #4
ALSO AVAILABLE

INLET AND DISCHARGE FLANGES TO MATE
FLUSH AND SQUARE WITH FLAT FACE
FLANGES ONLY. USE FULL FACE GASKETS

FOR V-BELT DRIVEN UNITS
MOTOR TO BE LOCATED ON
DRIVE SHAFT SIDE OF BLOWER

	8"FLG	10"FLG	12"FLG
OPENING	8.00	10.00	12.00
BOLT CIRCLE	11.75	14.25	17.00
FLANGE O.D.	13.50	16.00	19.00
NO TAPPED HOLES	8	12	12
SIZE HOLES	3/4-10	7/8-9	7/8-9
TAP DEPTH	1.13	1.31	1.31

W - INLET
W' - DISCHARGE
AD - SHEAVE WIDTH
AE - SHEAVE DIAMETER
H

ALL DIMENSIONS IN INCHES

700 RCS-JH BLOWER

FRAME SIZE	A	B	C	D	E	F	G	H	J	K	M	N	O	P	U	V	KEYWAY	W	W'	AA	AB	AD	AE	APPROX WEIGHT
715	26.00	21.50	33.88	10.00	10.75	9.63	.50	1.00	4.50	3.00	12.50	4.56	19.00	23.25	2.375	3.00	.625x.313	10"FLG	8"FLG	9.00	11.63	4.43	11.80	1100
721	"	27.00	39.38	"	"	12.38	"	"	"	"	15.25	"	"	"	"	"	"	12"FLG	10"FLG	"	"	"	"	1200

B- REVISED APPROX. WEIGHT JHB 10-21-93
A- REVISED PER ECN 3698-V RE 2/5/93

FR
2/5/93

DB

BA

70899021

70899a21

/PARTS1/XXAD

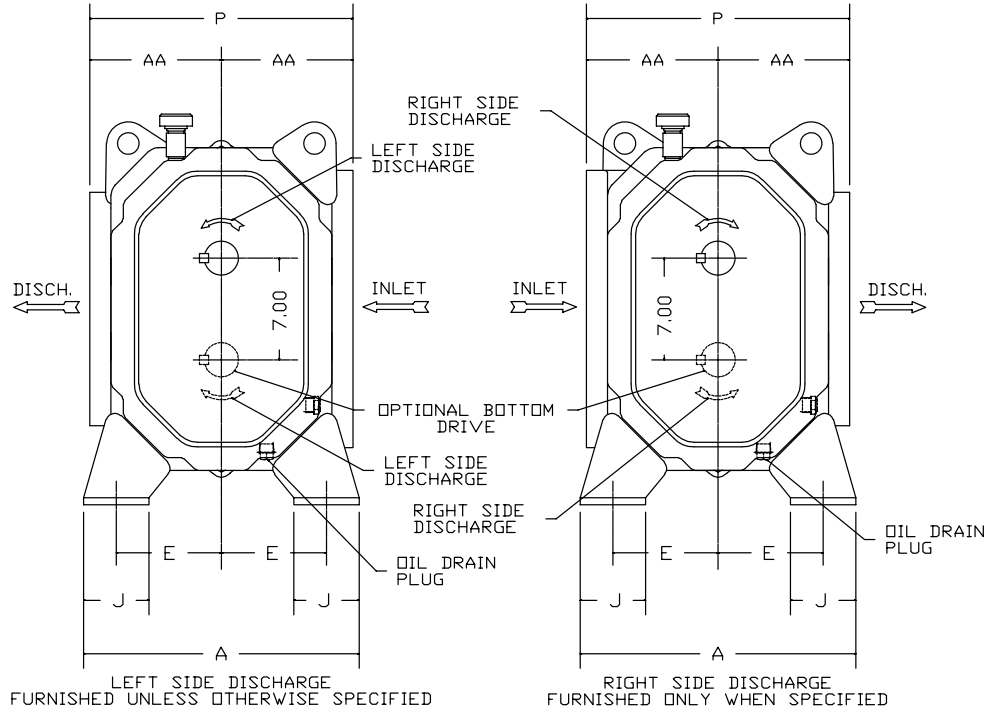
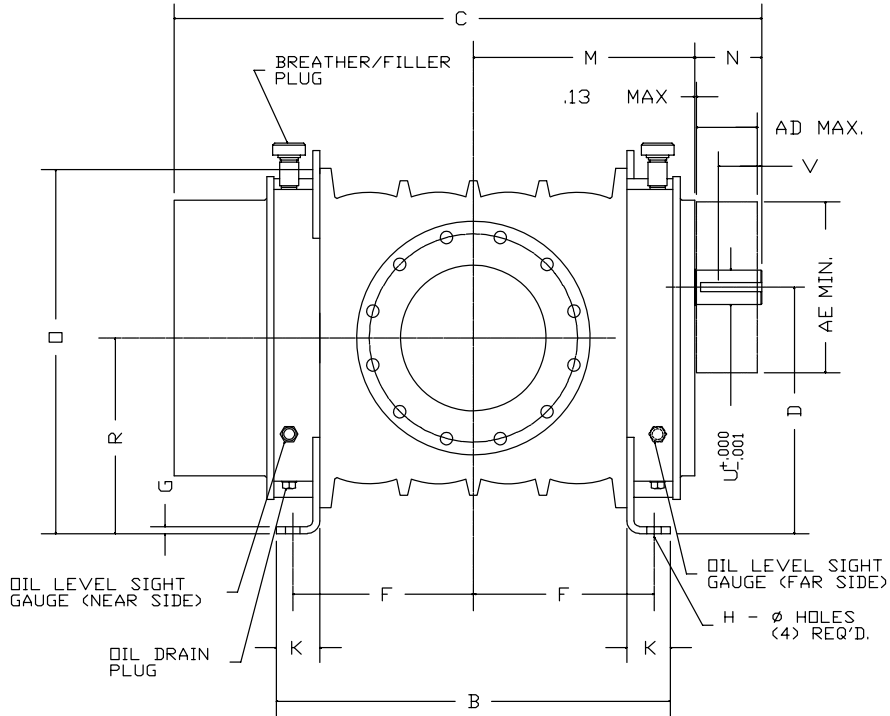

INLET AND DISCHARGE FLANGES TO MATE FLUSH AND SQUARE WITH FLAT FACE FLANGES ONLY. USE FULL FACE GASKETS

FOR V-BELT DRIVEN UNITS MOTOR TO BE LOCATED ON INLET SIDE OF BLOWER

	8"FLG	10"FLG	12"FLG
OPENING	8.00	10.00	12.00
BOLT CIRCLE	11.75	14.25	17.00
FLANGE O.D.	13.50	16.00	19.00
No TAPPED HOLES	8	12	12
SIZE HOLES	3/4-10	7/8-9	7/8-9
TAP DEPTH	1.13	1.31	1.31

W - INLET
W' - DISCHARGE
AD - SHEAVE WIDTH
AE - SHEAVE DIAMETER
H

ALL DIMENSIONS IN INCHES

700 RCS-JV BLOWER

FRAME SIZE	A	B	C	D	E	F	G	H	J	K	M	N	O	P	R	U	V	KEYWAY	W	W'	AA	AD	AE	APPROX WEIGHT
715	19.00	21.50	33.88	17.00	7.25	9.63	.50	1.00	4.50	3.00	12.50	4.56	25.13	18.00	13.50	2.375	3.00	.625x.313	10"FLG	8"FLG	9.00	4.43	11.80	1100
721	"	27.00	39.38	"	"	12.38	"	"	"	"	15.25	"	"	"	"	"	"	"	12"FLG	10"FLG	"	"	"	1200

B-REVISED APPROX. WEIGHT JHB 10-21-93
A-REVISED PER ECN 3698-V RVE 2/5/93

FR
1/7/91

DB

BA

70898021
70898a21

/PARTS1/XXAD